

Part III

Second Law of Thermodynamics

In this Part, we introduce the **second law of thermodynamics**, which asserts that

- processes occur in a certain direction and that
- energy has quality as well as quantity.
- A process cannot take place unless it satisfies both the first and second laws of thermodynamics.

In this chapter, the thermal energy reservoirs, reversible and irreversible processes, heat engines, refrigerators, and heat pumps are introduced first. Various statements of the second law are followed by a discussion of perpetual-motion machines and the absolute thermodynamic temperature scale. The Carnot cycle is introduced next, and the Carnot principles are examined. Finally, idealized Carnot heat engines, refrigerators, and heat pumps are discussed.

Introduction

In the preceding two chapters, we applied the *first law of thermodynamics*, or the *conservation of energy principle*, to processes involving closed systems. Energy is a conserved property, and no process is known to have taken place in violation of the first law of thermodynamics. Therefore, it is reasonable to conclude that a process must satisfy the first law to occur. However, as explained below, satisfying the first law alone does not ensure that the process will actually take place.

It is common experience that a cup of hot coffee left in a cooler room eventually cools off.



This process satisfies the first law of thermodynamics since the amount of energy lost by the coffee is equal to the amount gained by the surrounding air. Now let us consider the reverse process—the hot coffee getting even hotter in a cooler room as a result of heat transfer from the room air. We all know that this process never takes place. Yet, doing so would not violate the first law as long as the amount of energy lost by the air is equal to the amount gained by the coffee.

It is clear from the above that processes proceed in a *certain direction* and not in the reverse direction. The first law places no restriction on the direction of a process, but satisfying the first law does not ensure that that process will actually occur. This inadequacy of the first law to identify whether a process can take place is remedied by introducing another general principle, the *second law of thermodynamics*. We show later in this chapter that the reverse processes discussed above violate the second law of thermodynamics. This violation is easily detected with the help of a property, called *entropy*, defined in the next part. *A process will not occur unless it satisfies both the first and the second laws of thermodynamics.*

The second law has been stated in several ways.

(i) *The principle of Thomson (Lord Kelvin)* states: 'It is impossible by a cyclic process to take heat from a reservoir and to convert it into work without simultaneously transferring heat from a hot to a cold reservoir.' This statement of the second law is related to equilibrium, i.e. work can be obtained from a system only when the system is not already at equilibrium. If a system is at equilibrium, no spontaneous process occurs and no work is produced. Evidently, Kelvin's principle indicates that the spontaneous process is the heat flow from a higher to a lower temperature, and that only from such a spontaneous process can work be obtained.

(ii) *The principle of Clausius* states: 'It is impossible to devise an engine which, working in a cycle, shall produce no effect other than the transfer of heat from a colder to a hotter body.' A good example of this principle is the operation of a refrigerator.

(iii) *The principle of Planck* states: 'It is impossible to construct an engine which, working in a complete cycle, will produce no effect other than raising of a weight and the cooling of a heat reservoir.'

(iv) *The Kelvin-Planck principle* may be obtained by combining the principles of Kelvin and of Planck into one equivalent statement as the Kelvin-Planck statement of the second law. It states: 'No process is possible whose sole result is the absorption of heat from a reservoir and the conversion of this heat into work.'

The second law of thermodynamics is also used in determining the *theoretical limits* for the performance of commonly used engineering systems, such as heat engines and refrigerators, as well as predicting the *degree of completion* of chemical reactions.

The second law is not a deduction from the first law but a separate law of nature, referring to an aspect of nature different from that contemplated by the first law. The first law denies the possibility of creating or destroying energy, whereas the second law denies the possibility of utilizing energy in a particular way. The continuous operation of a machine that creates its own energy and thus violates the first law is called *perpetual motion of the first kind*. A cyclic device which would continuously abstract heat from a single reservoir and convert that heat completely to mechanical work is called a *perpetual-motion machine of the second kind*. Such a machine would not violate the first law (the principle of conservation of energy), since it would not create energy, but economically it would be just as valuable as if it did so. Hence, the second law is sometimes stated as follows: '*A perpetual motion machine of the second kind is impossible.*'

Thermal Energy Reservoir

In the development of the second law of thermodynamics, it is very convenient to have a hypothetical body with a relatively large *thermal energy capacity* (mass x specific heat) that can supply or absorb finite amounts of heat without undergoing any change in temperature. Such a body is called a **thermal energy reservoir**, or just a reservoir. In practice, large bodies of water such as oceans, lakes, and rivers as well as the atmospheric air can be modeled accurately as thermal energy reservoirs because of

their large thermal energy storage capabilities or thermal masses.

A body does not actually have to be very large to be considered a reservoir. Any physical body whose thermal energy capacity is large relative to the amount of energy it supplies or absorbs can be modeled as one. The air in a room, for example, can be treated as a reservoir in the analysis of the heat dissipation from a TV set in the room, since the amount of heat transfer from the TV set to the room air is not large enough to have a noticeable effect on the room air temperature.

A reservoir that supplies energy in the form of heat is called a **source**, and one that absorbs energy in the form of heat is called a **sink** (Fig. 5-7). Thermal energy reservoirs are often referred to as **heat reservoirs** since they supply or absorb energy in the form of heat.

Heat Engines

Work can easily be converted to other forms of energy, but converting other forms of energy to work is not that easy. The mechanical work done by a propeller placed in a bucket of water, for example, is first converted to the internal energy of the water. This energy may then leave the water as heat. We know from experience that any attempt to reverse this process will fail. That is, transferring heat to the water will not cause the shaft to rotate. From this and other observations, we conclude that *work can be converted to heat directly and completely, but converting heat to work requires the use of some special devices. These devices are called heat engines.*

Heat engines differ considerably from one another, but all can be characterized by the following.

- They receive heat from a high-temperature source (solar energy, oil furnace, nuclear reactor, etc.).
- They convert part of this heat to work (usually in the form of a rotating shaft).
- They reject the remaining waste heat to a low-temperature sink (the atmosphere, rivers, etc.).
- They operate on a cycle

Heat engines and other cyclic devices usually involve a fluid to and from which heat is transferred while undergoing a cycle. This fluid is called the **working fluid**.

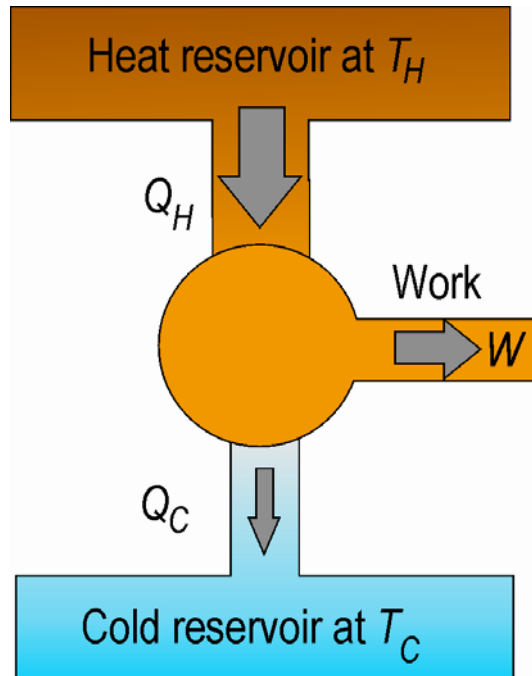

Note: The term *heat engine* is often used in a broader sense to include work-producing devices that do not operate in a thermodynamic cycle. Engines that involve internal combustion such as gas turbines and car engines fall into this category. These devices operate in a mechanical cycle but not in a thermodynamic cycle since the working fluid (the combustion gases) does not undergo a complete cycle. Instead of being cooled to the initial temperature, the exhaust gases are purged and replaced by fresh air-and-fuel mixture at the end of the cycle.

The work-producing device that best fits into the definition of a heat engine is the *steam power plant*, which is an external-combustion engine. That is, the combustion process takes place outside the engine, and the thermal energy released during this process is transferred to the steam as heat. The schematic of a basic steam power plant is shown below

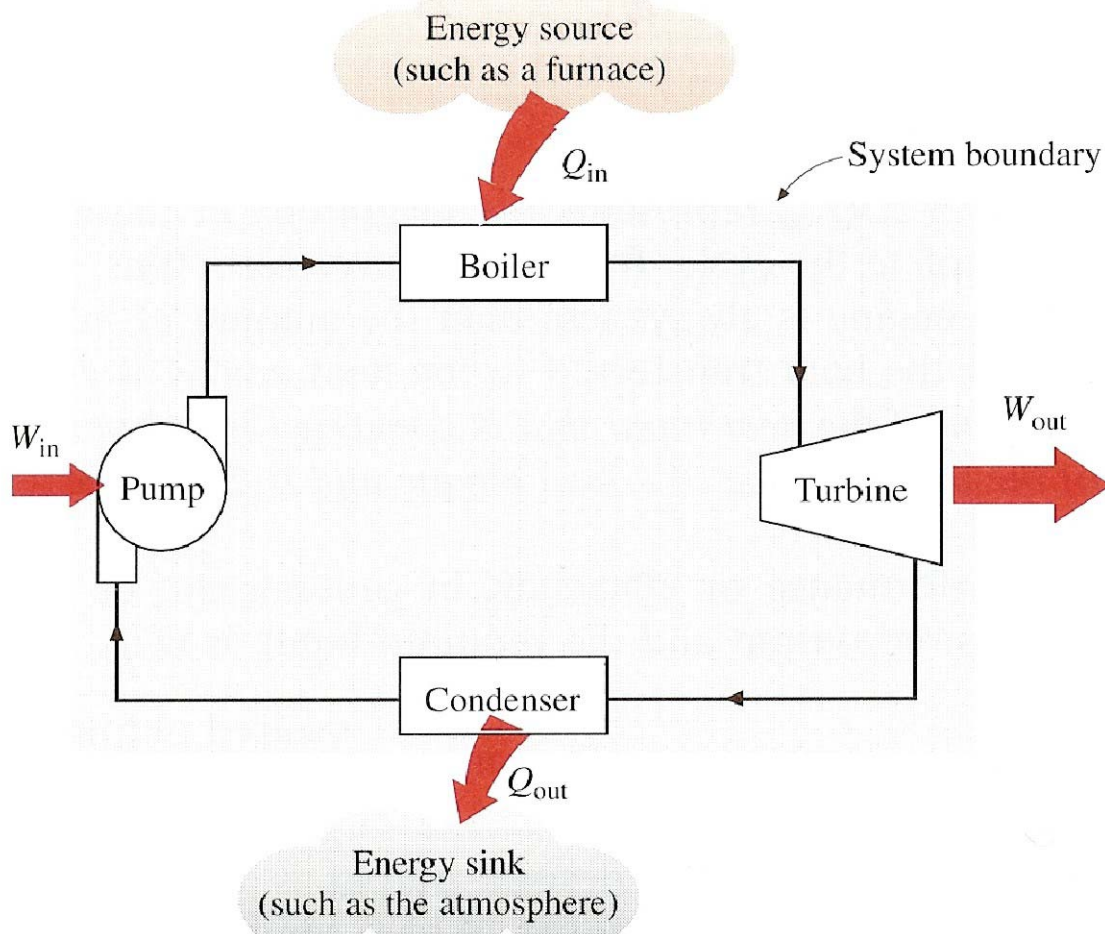

The various quantities shown on this figure are as follows

Q_{in} = amount of heat supplied to steam in boiler from a high temperature source (furnace)

Q_{out} = amount of heat rejected from steam in condenser to a low temperature sink (the atmosphere, a river, etc.)

W_{out} = amount of work delivered by steam as it expands in turbine

W_{in} = amount of work required to compress water to boiler pressure

Above the quantities are indicated with *in* and *out*, and they are all positive

The net work output of this power plant is simply the difference between the total work output of the plant and the total work input.

$$W_{net\ out} = W_{out} - W_{in}$$

3-1

The net work can also be determined from the heat transfer data alone. For a closed system undergoing a cycle, the change in internal energy ΔU is zero, and therefore the net work **output of the system** is also equal to the **net heat transfer to the system**:

$$W_{net\ out} = Q_{in} - Q_{out} \quad 3-2$$

Thermal Efficiency

In Eq. 3-2, Q_{out} represents the magnitude of the energy wasted in order to complete the cycle. But Q_{out} is never zero; thus, the net work output of a heat engine is always less than the amount of heat input. That is, only part of the heat transferred to the heat engine is converted to work. *The fraction of the heat input that is converted to net work output is a measure of the performance of a heat engine and is called the **thermal efficiency**.*

Performance or efficiency, in general, can be expressed in terms of the desired output and the required input as

$$\text{Performance} = \text{desired output} / \text{required input} \quad 3-3$$

or,

$$\eta = W_{net\ out} / Q_{in} \quad 3-4$$

or

$$\eta = 1 - Q_{out} / Q_{in} \quad 3-4$$

Cyclic devices such as heat engines, refrigerators, and heat pumps operate between a high-temperature medium (or reservoir) at temperature T_H and a low-temperature medium (or reservoir) at temperature T_L . To bring uniformity to the treatment of heat engines, refrigerators, and heat pumps, we define the following two quantities

$Q_H = \text{magnitude}$ of heat transfer between cyclic device and high temperature medium at temperature T_H

$Q_L = \text{magnitude}$ of heat transfer between cyclic device and low temperature medium at temperature T_L

Note: Q_L and Q_H are defined as *magnitudes* and therefore are *positive quantities*. The

direction of Q_H and Q_L is easily determined by inspection, and we do not need to be concerned about their signs. Then the net work output and thermal efficiency relations for any heat engine (shown in Fig. 5-14) can also be expressed as

$$W_{net\ out} = Q_H - Q_L \quad 3-5$$

$$\eta = W_{net\ out} / Q_H \quad 3-6$$

$$\eta = 1 - Q_L / Q_H \quad 3-4$$

The thermal efficiency of a heat engine is always less than unity since both Q_L and Q_H are defined as positive quantities.

Note: The thermal efficiencies of work-producing devices are amazingly low. Ordinary spark-ignition automobile engines have a thermal efficiency of about 20 percent. That is, an automobile engine converts, at an average, about 20 percent of the chemical energy of the gasoline to mechanical work. This number is about 30 percent for diesel engines and large gas-turbine plants and 40 percent for large steam power plants. Thus, even with the most efficient heat engines available today, more than one-half of the energy supplied ends up in the rivers, lakes, or the atmosphere as waste or unusable energy.

Can We Save Q_{out} ?

In a steam power plant, the condenser is the device where large quantities of waste heat is rejected to rivers, lakes, or the atmosphere. Then one may ask, can we not just take the condenser out of the plant and save all that waste energy? The answer to this question is *no* for the simple reason that without the cooling process in a condenser the cycle cannot be completed. (Cyclic devices such as steam power plants cannot run continuously unless the cycle is completed.) This is demonstrated below with the help of a simple heat engine.

Consider the simple heat engine shown below that is used to lift weights. It consists of a piston-cylinder device with two sets of stops. The working fluid is the gas contained within the cylinder. Initially, the gas temperature is 30°C.

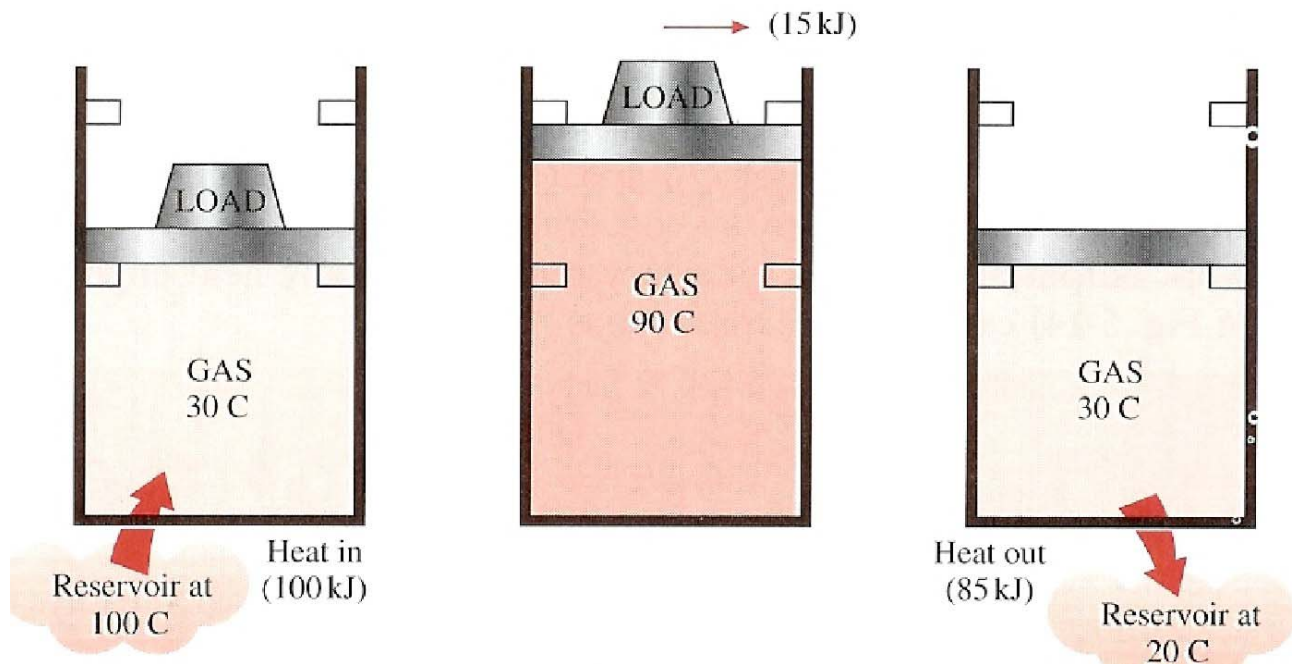

The piston, which is loaded with the weights, is resting on top of the lower stops. Now 100 kJ of heat is transferred to the gas in the cylinder from a source at 100°C, causing it to expand and to raise the loaded piston until the piston reaches the upper stops, as shown in the figure. At this point, the load is removed, and the gas temperature is observed to be 90°C

The work done on the load during this expansion process is equal to the increase in its potential energy, say 15 kJ. Even under ideal conditions (weightless piston, no friction, no heat losses, and quasi-equilibrium expansion), the amount of heat supplied to the gas is greater than the work done since part of the heat supplied is used to raise the temperature of the gas.

Now let us try to answer the following question: *Is it possible to transfer the 85 kJ of excess heat at 90°C back to the reservoir at 100°C for later use?* If it is, then we will have a heat engine that can have a thermal efficiency of 100 percent under ideal conditions. The answer to this question is again *no*, for the very simple reason that heat always flows from a high-temperature medium to a low-temperature one, and never the other way around. Therefore, we cannot cool this gas from 90 to 300e by transferring heat to a reservoir at 100°C. Instead, we have to bring the system into contact with a low-temperature reservoir, say at 20°C, so that the gas can return to its initial state by rejecting its 85 kJ of excess

energy as heat to this reservoir. This energy cannot be recycled, and it is properly called *waste energy*.

We conclude from the above discussion that every heat engine must *waste* some energy by transferring it to a low-temperature reservoir in order to complete the cycle, even under idealized conditions. The requirement that a heat engine exchange heat with at least two reservoirs for continuous operation forms the basis for the Kelvin-Planck expression of the second law of thermodynamics discussed later in this section.

Example 3.1

Heat is transferred to a heat engine from a furnace at a rate of 80 MW. If the rate of waste heat rejection to a nearby river is 50 MW, determine the net power output and the thermal efficiency for this heat engine.

Solution

A schematic of the heat engine is given below. The furnace serves as the high-temperature reservoir for this heat engine and the river as the low-temperature reservoir. Then the given quantities can be expressed in rate form as

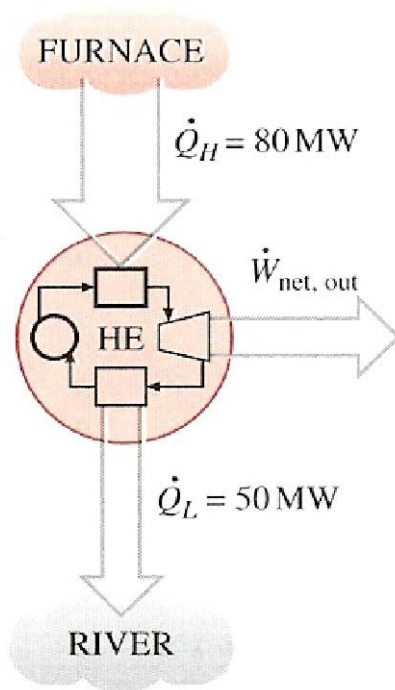

$$\dot{Q}_H = 80 \text{ MW} \quad \dot{Q}_L = 50 \text{ MW}$$

The net power output is $\dot{W}_{net.out} = \dot{Q}_H - \dot{Q}_L = 30 \text{ MW}$

Thus, $\eta = \dot{W}_{net.out} / \dot{Q}_H = 0.375$

The Second Law of Thermodynamics: Kelvin-Planck Statement

No heat engine can convert all the heat it receives to useful work. This limitation on the thermal efficiency of heat engines forms the basis for the Kelvin-Planck statement of the second law of thermodynamics, which is expressed as follows:

- *It is impossible for any device that operates on a cycle to receive heat from a single reservoir and produce a net amount of work.*
- The Kelvin-Planck statement can also be expressed as follows: *No heat engine can have a thermal efficiency of 100 percent, or for a power plant to operate, the working fluid must exchange heat with the environment as well as the furnace.*

Note The impossibility of having a 100 percent efficient heat engine is not due to friction or other dissipative effects. It is a limitation that applies to both the idealized and the actual heat engines.

Refrigerators and Heat Pumps

We all know from experience that heat flows in the direction of decreasing temperature, i.e., from high-temperature mediums to low temperature ones. This heat transfer process occurs in nature without requiring any devices. The reverse process, however, cannot occur by itself. The transfer of heat from a low-temperature medium to a high-temperature one requires special devices called refrigerators.

Refrigerators, like heat engines, are cyclic devices. The working fluid used in the refrigeration cycle is called a refrigerant. The most frequently used refrigeration cycle is the *vapor-compression refrigeration cycle* which involves four main components: a compressor, a condenser, an expansion valve, and an evaporator, as shown below

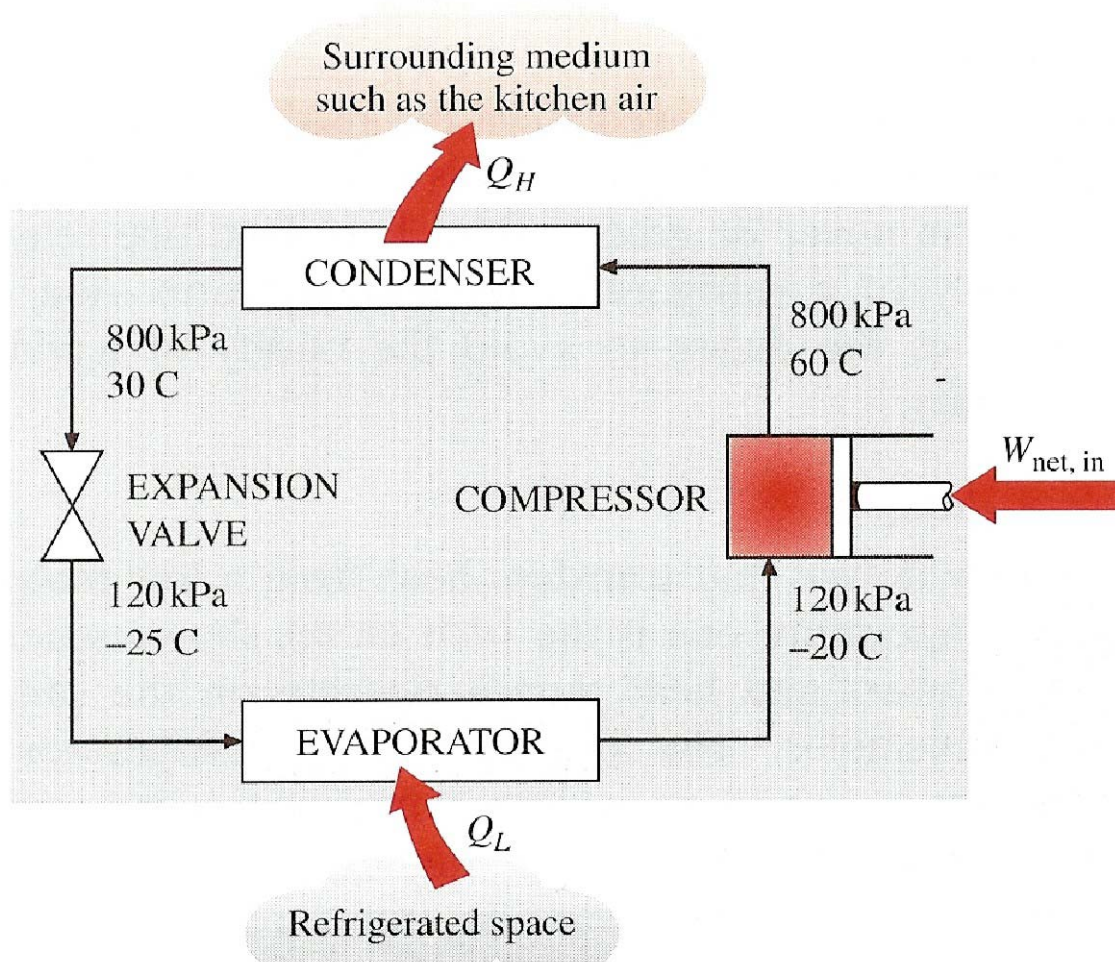

The refrigerant enters the compressor as a vapor and is compressed to the condenser pressure. It leaves the compressor at a relatively high temperature and cools down and condenses as it flows through the coils of the condenser by rejecting heat to the surrounding medium. It then enters a capillary tube where its pressure and temperature drop drastically due to the throttling effect. The low-temperature refrigerant then enters the evaporator, where it evaporates by absorbing heat from the refrigerated space. The cycle is completed as the refrigerant leaves the evaporator and reenters the compressor.

In a household refrigerator, the freezer compartment where heat is picked up by the refrigerant serves as the evaporator, and the coils behind the refrigerator where heat is dissipated to the kitchen air as the condenser.

A refrigerator is shown schematically below. Here Q_L is the magnitude of the heat removed from the refrigerated space at temperature T_L , Q_H is the magnitude of the heat rejected to the warm environment at temperature T_H' and $W_{net, in}$ is the net work input to the refrigerator. As discussed before, Q_L and Q_H represent magnitudes and so are positive quantities.

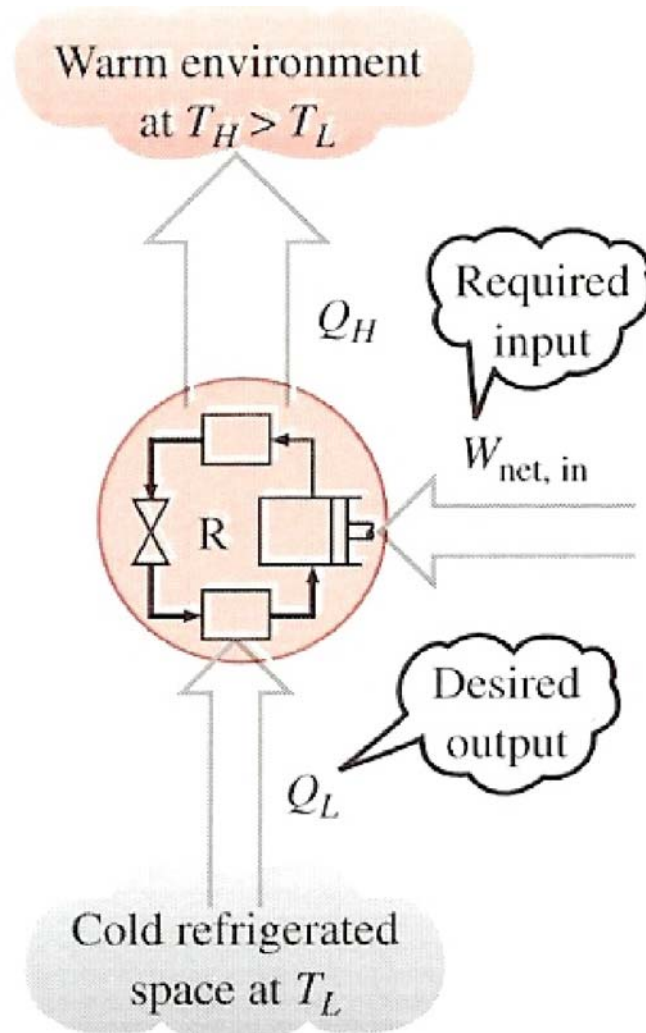

Coefficient of Performance

The *efficiency* of a refrigerator is expressed in terms of the coefficient of performance (COP), denoted by COP_R . The objective of a refrigerator is to remove heat (Q_L) from the refrigerated space. To accomplish this objective, it requires a work input of $W_{net,in}$. Then the COP of a refrigerator can be expressed as

$$COP_R = \text{desired output} / \text{required input} = Q_L / W_{net,in} \quad 3-5$$

or

$$COP_R = \frac{Q_L}{Q_H - Q_L} \quad 3-6$$

Note The value of COPR can be *greater than unity*. That is, the amount of heat removed from the refrigerated space can be greater than the amount of work input. This is

in contrast to the thermal efficiency, which can never be greater than 1. In fact, one reason for expressing the efficiency of a refrigerator by another term—the coefficient of performance—is the desire to avoid the oddity of having efficiencies greater than unity.

Heat Pumps

Another device that transfers heat from a low-temperature medium to a high-temperature one is the heat pump. Refrigerators and heat pumps operate on the same cycle but differ in their objectives. The objective of a refrigerator is to maintain the refrigerated space at a low temperature by removing heat from it. Discharging this heat to a higher-temperature medium is merely a necessary part of the operation, not the purpose. The objective of a heat pump, however, is to maintain a heated space at a high temperature. This is accomplished by absorbing heat from a low-temperature source, such as well water or cold outside air in winter, and supplying this heat to the high-temperature medium such as a house.

An ordinary refrigerator that is placed in the window of a house with its door open to the cold outside air in winter will function as a heat pump since it will try to cool the outside by absorbing heat from it and rejecting this heat into the house through the coils behind it.

The measure of performance of a heat pump is also expressed in terms of the coefficient of performance COP_{HP} , defined as

$$COP_{HP} = \frac{Q_H}{Q_H - Q_L} \quad 3-7$$

$$COP_{HP} = COP_R + 1 \quad 3-8$$

The relation implies that the coefficient of performance of a heat pump is always greater than unity since COP_R is a positive quantity. That is, a heat pump will function, at worst, as a resistance heater, supplying as much energy to the house as it consumes. In reality, however, part of Q_H is lost to the outside air through piping and other devices, and COP_{HP} may drop below unity when the outside air temperature is too low. When this happens, the system usually switches to a resistance heating mode. Most heat pumps in operation today have seasonally averaged COP of 2 to 3.

The Second Law of Thermodynamics: Clausius Statement

Clausius statement is related to refrigerators or heat pumps. The Clausius statement is expressed as follows:

It is impossible to construct a device that operates in a cycle and produces no effect other than the transfer of heat from a lower temperature body to a higher-temperature body.

It is common knowledge that heat does not, of its own volition, flow from a cold medium to a warmer one. The Clausius statement does not imply that a cyclic device that transfers heat from a cold medium to a warmer one is impossible to construct. In fact, this is precisely what a common household refrigerator does. It simply states that a refrigerator will not operate unless its compressor is driven by an external power source, such as an electric motor. This way, the net effect on the surroundings involves the consumption of some energy in the form of work, in addition to the transfer of heat from a colder body to a warmer one. That is, it leaves a trace in the surroundings. Therefore, a household refrigerator is in complete compliance with the Clausius statement of the second law.

Both the Kelvin-Planck and the Clausius statements of the second law are negative statements, and a negative statement cannot be proved. Like any other physical law, the second law of thermodynamics is based on experimental observations. To date, no experiment has been conducted that contradicts the second law, and this should be taken as sufficient evidence of its validity.

Equivalence of the Two Statements

The Kelvin-Planck and the Clausius statements are equivalent in their consequences, and either statement can be used as the expression of the second law of thermodynamics. Any device that violates the Kelvin-Planck statement also violates the Clausius statement, and vice versa. This can be demonstrated as follows:

Consider the heat-engine-refrigerator combination shown in figure below left, operating between the same two reservoirs.

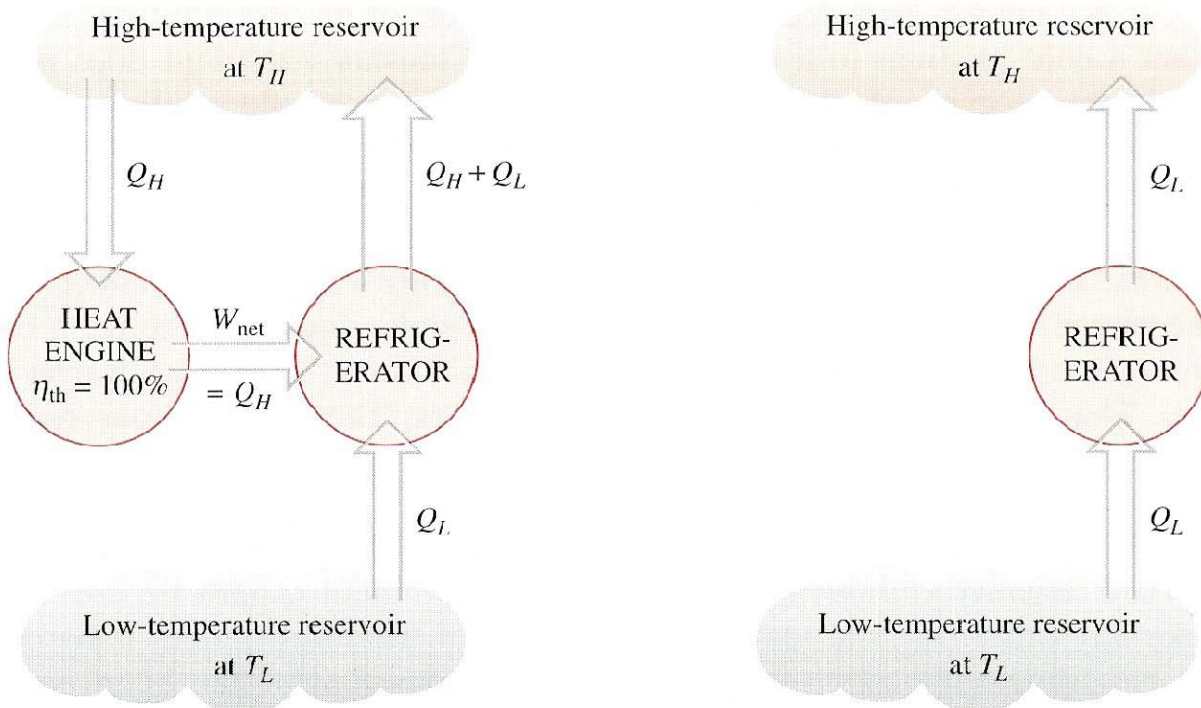

The heat engine is assumed to have, in violation of the Kelvin-Planck statement, a thermal efficiency of 100 percent, and therefore it converts all the heat Q_H it receives to work W . This work is now supplied to a refrigerator that removes heat in the amount of Q_L from the low-temperature reservoir and rejects heat in the amount of $Q_L + Q_H$ to the high-temperature reservoir. During this process, the high-temperature reservoir receives a net amount of heat Q_L (the difference between $Q_L + Q_H$ and Q_H). Thus the combination of these two devices can be viewed as a refrigerator, as shown in figure at right, that transfers heat in an amount of Q_L from a cooler body to a warmer one without requiring any input from outside. This is clearly a violation of the Clausius statement. Therefore, a violation of the Kelvin-Planck statement results in the violation of the Clausius statement.

It can also be shown in a similar manner that a violation of the Clausius statement leads to the violation of the Kelvin-Planck statement. Therefore, the Clausius and the Kelvin-Planck statements are two equivalent expressions of the second law of thermodynamics.

PERPETUAL MOTION MACHINES

We have repeatedly stated that a process cannot take place unless it satisfies both the first and second laws of thermodynamics. Any device that violates either law is called a perpetual-motion machine, and despite numerous attempts, no perpetual-motion machine is known to have worked. But this has not stopped inventors from trying to create new ones.

A device that violates the first law of thermodynamics (by *creating energy*) is called a *perpetual-motion machine of the first kind* (PMM1), and a device that violates the second law of thermodynamics is called a *perpetual-motion machine of the second kind* (PMM2).

Consider the steam power plant shown below

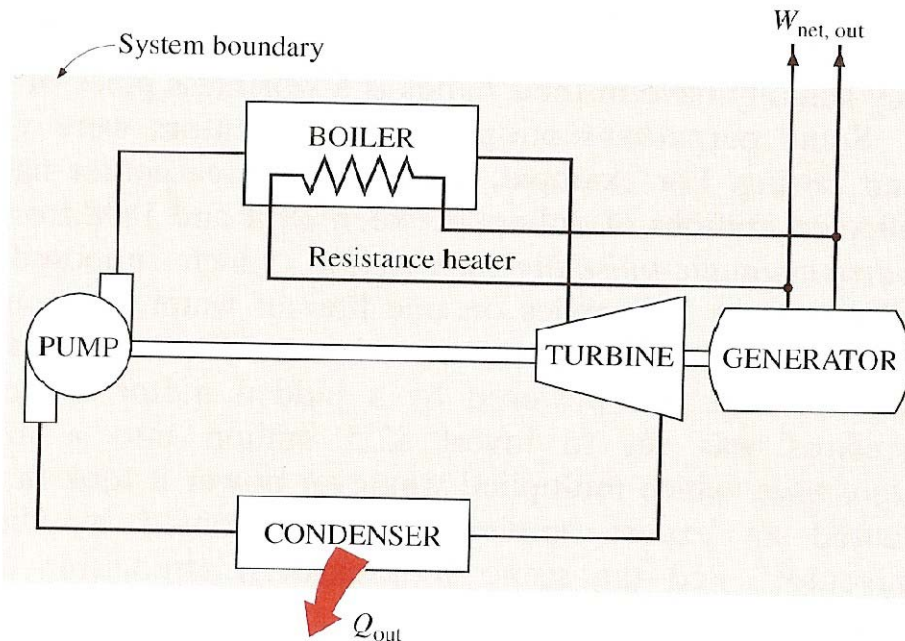

It is proposed to heat the steam by resistance heaters placed inside the boiler, instead of by the energy supplied from fossil or nuclear fuels. Part of the electricity generated by the plant is to be used to power the resistors as well as the pump. The rest of the electric energy is to be supplied to the electric network as the net work output. The inventor claims that once the system is started, this power plant will produce electricity indefinitely without requiring any energy input from the outside.

Well, here is an invention that could solve the world's energy problem-if it works, of course. A careful examination of this invention reveals that the system enclosed by the shaded area is continuously supplying energy to the outside at a rate of $Q_{out} + W_{net,out}$ every

second without receiving any energy. That is, this system is creating energy at a rate of $Q_{out} + W_{net,out}$, which is clearly a violation of the first law. Therefore, this wonderful device is nothing more than a PMM1 and does not warrant any further consideration.

Now let us consider another novel idea by the same inventor. Convinced that energy cannot be created, the inventor suggests the following modification which will greatly improve the thermal efficiency of that power plant without violating the first law. Aware that more than one-half of the heat transferred to the steam in the furnace is discarded in the condenser to the environment, the inventor suggests getting rid of this wasteful component and sending the steam to the pump as soon as it leaves the turbine, as shown below

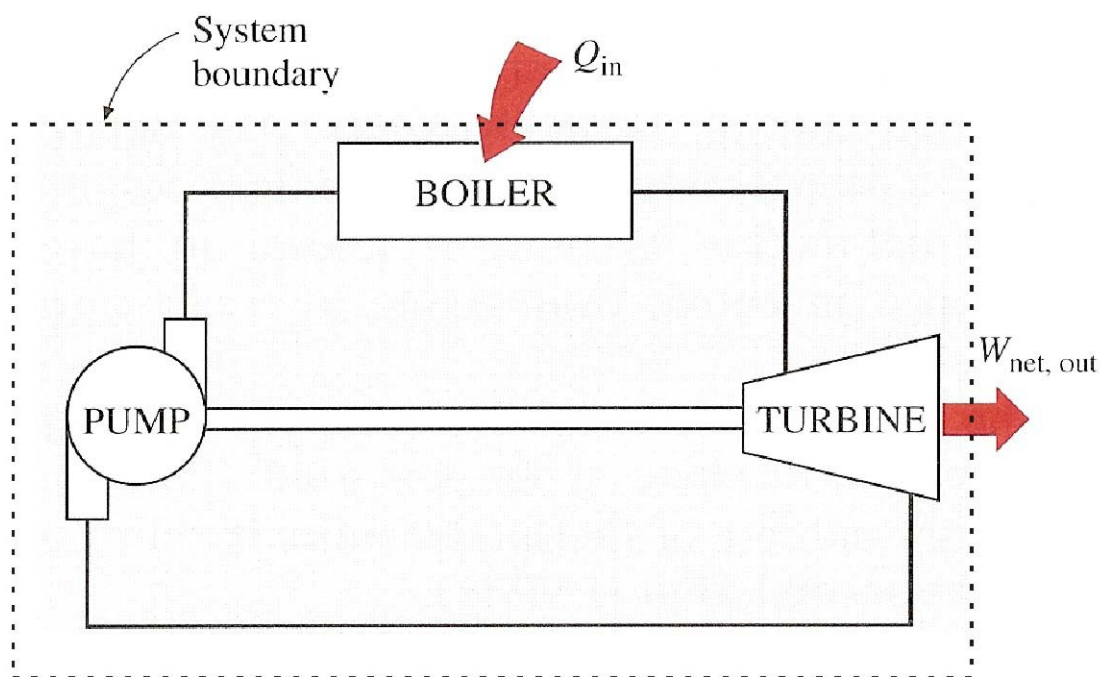

This way, all the heat transferred to the steam in the boiler will be converted to work, and thus the power plant will have a theoretical efficiency of 100 percent. The inventor realizes that some heat losses and friction between the moving components are unavoidable and that these effects will hurt the efficiency somewhat, but still expects the efficiency to be no less than 80 percent (as opposed to 40 percent in actual power plants) for a carefully designed system.

Well, the possibility of doubling the efficiency would certainly be very tempting to plant managers and, if not properly trained, they would probably give this idea a chance, since intuitively they see nothing wrong with it. A student of thermodynamics, however, will immediately label this device as a PMM2, since it works on a cycle and does a net amount of work while exchanging heat with a single reservoir (the furnace) only. It

satisfies the first law but violates the second law, and therefore it will not work.

Note: Countless perpetual-motion machines have been proposed throughout history, and many more are being proposed. Some proposers have even gone so far as patenting their inventions, only to find out that what they actually have in their hands is a worthless piece of paper.

Some perpetual-motion machine inventors were very successful in fund raising. For example, a Philadelphia carpenter named J. W. Kelly collected millions of dollars between 1874 and 1898 from investors in his *hydropneumatic-pulsating-vacu-engine*, which supposedly could push a railroad train 3000 miles on one liter of water. Of course it never did. After his death in 1898, the investigators discovered that the demonstration machine was powered by a hidden motor. Recently a group of investors was set to invest \$2.5 million into a mysterious *energy augmentor*, which multiplied whatever power it took in, but their lawyer wanted an expert opinion first. Confronted by the scientists, the "inventor" fled the scene without even attempting to run his demo machine.

Reversible and Irreversible Processes

The second law of thermodynamics states that no heat engine can have an efficiency of 100 percent. Then what is the highest efficiency that a heat engine *can* possibly have? Before we can answer this question, we need to define an idealized process first, which is called the *reversible process*.

The processes that were discussed above occurred in a certain direction. Once having taken place, these processes cannot reverse themselves spontaneously and restore the system to its initial state. For this reason, they are classified as *irreversible processes*. Once a cup of hot coffee cools, it will not heat up retrieving the heat it lost from the surroundings. If it could, the surroundings, as well as the system (coffee), would be restored to their original condition, and this would be a *reversible process*.

A reversible process is defined as a *process that can be reversed without leaving any trace on the surroundings*. That is, both the system and the surroundings are returned to their initial states at the end of the reverse process. This is possible only if the net heat *and* net work exchange between the system and the surroundings is zero for the combined (original and reverse) process. Processes that are not reversible are called irreversible processes.

It should be pointed out that a system can be restored to its initial state following a

process, regardless of whether the process is reversible or irreversible. But for reversible processes, this restoration is made without leaving any net change on the surroundings, whereas for irreversible processes, the surroundings usually do some work on the system and therefore will not return to their original state.

Reversible processes actually do not occur in nature. They are merely *idealizations* of actual processes. Reversible processes can be approximated by actual devices, but they can never be achieved. That is, all the processes occurring in nature are irreversible. You may be wondering, then, *why* we are bothering with such fictitious processes. There are two reasons. First, they are easy to analyze, since a system passes through a series of equilibrium states during a reversible process; second, they serve as idealized models to which actual processes can be compared.

Engineers are interested in reversible processes because **work-producing** devices such as car engines and gas or steam turbines *deliver the most work*, and **work-consuming** devices such as compressors, fans, and pumps *require least work* when reversible processes are used instead of irreversible ones.

Reversible processes can be viewed as *theoretical limits* for the corresponding irreversible ones. Some processes are more irreversible than others. We may never be able to have a reversible process, but we may certainly approach it. The more closely we approximate a reversible process, the more work delivered by a work-producing device or the less work required by a work-consuming device.

The concept of reversible processes leads to the definition of *second-law efficiency* for actual processes, which is the degree of approximation to the corresponding reversible processes. This enables us to compare the performance of different devices that are designed to do the same task on the basis of their efficiencies. The better the design, the lower the irreversibilities and the higher the second-law efficiency.

Irreversibilities

The factors that cause a process to be irreversible are called irreversibilities. They include

- friction,
- unrestrained expansion,
- mixing of two gases,
- heat transfer across a finite temperature difference,
- electric resistance,

- inelastic deformation of solids, and
- chemical reactions.

The presence of any of these effects renders a process irreversible. A reversible process involves none of these. Some of the frequently encountered irreversibilities are discussed briefly below.

Friction

Friction is a familiar form of irreversibility associated with bodies in motion. When two bodies in contact are forced to move relative to each, a friction force that opposes the motion develops at the interface of these two bodies, and some work is needed to overcome this friction force. The energy supplied as work is eventually converted to heat during the process and is transferred to the bodies in contact, as evidenced by a temperature rise at the interface. When the direction of the motion is reversed, the bodies will be restored to their original position, but the interface will not cool, and heat will not be converted back to work. Instead, more of the work will be converted to heat while overcoming the friction forces which also oppose the reverse motion. Since the system (the moving bodies) and the surroundings cannot be returned to their original states, this process is irreversible. Therefore, any process that involves friction is irreversible. The larger the friction forces involved, the more irreversible the process is.

Friction does not always involve two solid bodies in contact. It is also encountered between a fluid and solid and even between the layers of a fluid moving at different velocities. A considerable fraction of the power produced by a car engine is used to overcome the friction (the drag force) between the air and the external surfaces of the car, and it eventually becomes part of the internal energy of the air. It is not possible to reverse this process and recover that lost power, even though doing so would not violate the conservation of energy principle.

Non-Quasi-Equilibrium Expansion and Compression

In Part 1 we defined a quasi-equilibrium process as one during which the system remains infinitesimally close to a state of equilibrium at all times. Consider a frictionless adiabatic piston-cylinder device that contains a gas. Now the piston is pushed into the cylinder, compressing the gas. If the piston velocity is not very high, the pressure and the temperature will increase uniformly throughout the gas. Since the system is always maintained at a state close to equilibrium, this is a quasi-equilibrium process.

Now the external force on the piston is slightly decreased, allowing the gas to expand.

The expansion process will also be *quasi-equilibrium* if the gas is allowed to expand slowly. When the piston returns to its original position, all the boundary ($P dV$) work done on the gas during compression is returned to the surroundings during expansion. That is, the net work for the combined process is zero. Also, there has been no heat transfer involved during this process, and thus both the system and the surroundings will return to their initial states at the end of the reverse process. Therefore, the slow frictionless adiabatic expansion or compression of a gas is a reversible process.

Now let us repeat this adiabatic process in a *non-quasi-equilibrium* manner, as shown below.

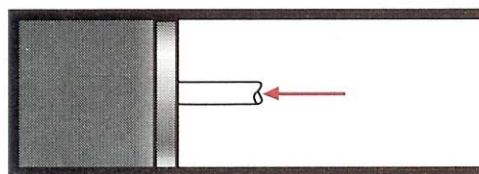

(a) Fast compression

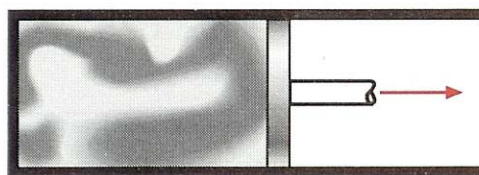

(b) Fast expansion



(c) Unrestrained expansion

If the piston is pushed in very rapidly, the gas molecules near the piston face will not have sufficient time to escape, and they will pile up in front of the piston. This will raise the pressure near the piston face, and as a result, the pressure there will be higher than the pressure in other parts of the cylinder. The non-uniformity of pressure will render this process non-quasi-equilibrium. The actual boundary work is a function of pressure, as measured at the piston face. Because of this higher pressure value at the piston face, a non-quasi-equilibrium compression process will require a larger work input than the corresponding quasi-equilibrium one. When the process is reversed by letting the gas expand rapidly, the gas molecules in the cylinder will not be able to follow the piston as fast, thus creating a low-pressure region before the piston face. Because of this low-

pressure value at the piston face, a non-quasi-equilibrium process will deliver less work than a corresponding reversible one. Consequently, the work done by the gas during expansion is less than the work done by the surroundings on the gas during compression, and thus the surroundings have a net work deficit. When the piston returns to its initial position, the gas will have excess internal energy, equal in magnitude to the work deficit of the surroundings.

The system can easily be returned to its initial state by transferring this excess internal energy to the surroundings as heat. But the only way the surroundings can be returned to their initial condition is by completely converting this heat to work, which can only be done by a heat engine that has an efficiency of 100 percent. This, however, is impossible to do, even theoretically, since it would violate the second law of thermodynamics. Since only the system, not both the system and the surroundings, can be returned to its initial state, we conclude that the adiabatic non-quasi-equilibrium expansion or compression of a gas is irreversible.

Another example of non-quasi-equilibrium expansion processes is the unrestrained expansion of a gas separated from a vacuum by a membrane, as shown above. When the membrane is ruptured, the gas fills the entire tank. The only way to restore the system to its original state is to compress it to its initial volume, while transferring heat from the gas until it reaches its initial temperature. From the conservation of energy considerations, it can easily be shown that the amount of heat transferred from the gas equals the amount of work done on the gas by the surroundings. The restoration of the surroundings involves conversion of this heat completely to work, which would violate the second law. Therefore, unrestrained expansion of a gas is an irreversible process.

Heat Transfer

Another form of irreversibility familiar to us all is heat transfer through a finite temperature difference.

Consider a can of cold soda left in a warm room. Heat will flow from the warmer room air to the cooler soda. The only way this process can be reversed and the soda restored to its original temperature is to provide refrigeration, which requires some work input. At the end of the reverse process, the soda will be restored to its initial state, but the surroundings will not be.

The internal energy of the surroundings will increase by an amount equal in magnitude to

the work supplied to the refrigerator. The restoration of the surroundings to its initial state can be done only by converting this excess internal energy completely to work, which is impossible to do without violating the second law. Since only the system, not both the system and the surroundings, can be restored to its initial condition, heat transfer through a finite temperature difference is an irreversible process.

Heat transfer can occur only when there is a temperature difference between a system and its surroundings. Therefore, it is physically impossible to have a reversible heat transfer process. But a heat transfer process becomes less and less irreversible as the temperature difference between the two bodies approaches zero. **Then heat transfer through a differential temperature difference dT can be considered to be reversible.** As dT approaches zero, the process can be reversed in direction (at least theoretically) without requiring any refrigeration. Notice that reversible heat transfer is a conceptual process and cannot be duplicated in the laboratory.

The smaller the temperature difference between two bodies, the smaller the heat transfer rate will be. When the temperature difference is small, any significant heat transfer will require a very large surface area and a very long time. Therefore, even though approaching reversible heat transfer is desirable from a thermodynamic point of view, it is impractical and not economically feasible.

Internally and Externally Reversible Processes

A process is an interaction between a system and its surroundings, and a reversible process involves no irreversibilities associated with either of them.

A process is called **internally reversible** if no irreversibilities occur within the boundaries of the system during the process. During an internally reversible process, a system proceeds through a series of equilibrium states, and when the process is reversed, the system passes through exactly the same equilibrium states while returning to its initial state. That is, the paths of the forward and reverse processes coincide for an internally reversible process. The quasi-equilibrium process discussed earlier is an example of an internally reversible process.

A process is called **externally reversible** if no irreversibilities occur outside the system boundaries during the process. Heat transfer between a reservoir and a system is an externally reversible process if the surface of contact between the system and the reservoir is at the temperature of the reservoir.

A process is called **totally reversible, or simply reversible, if it involves no**

irreversibilities within the system or its surroundings.

A totally reversible process involves no heat transfer through a finite temperature difference, no non-quasi-equilibrium changes, and no friction or other dissipative effects.

As an example, consider the transfer of heat to two identical systems that are undergoing a constant-pressure (thus constant-temperature) phase-change process, as shown in figure below. Both processes are internally reversible, since both take place isothermally and both pass through exactly the same equilibrium states. The first process shown is externally reversible also, since heat transfer for this process takes place through an infinitesimal temperature difference dT . The second process, however, is externally irreversible, since it involves heat transfer through a finite temperature difference ΔT .

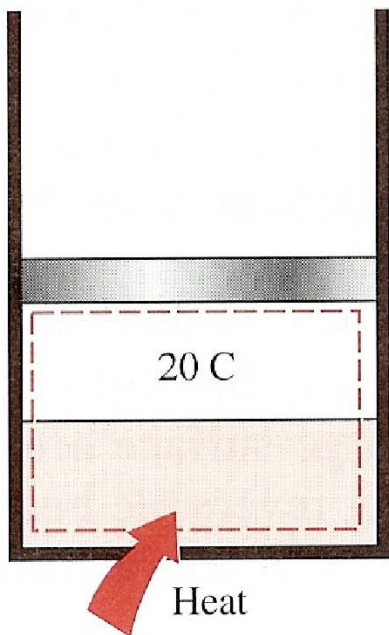

Thermal energy
reservoir at 20.001 C

(a) Totally reversible

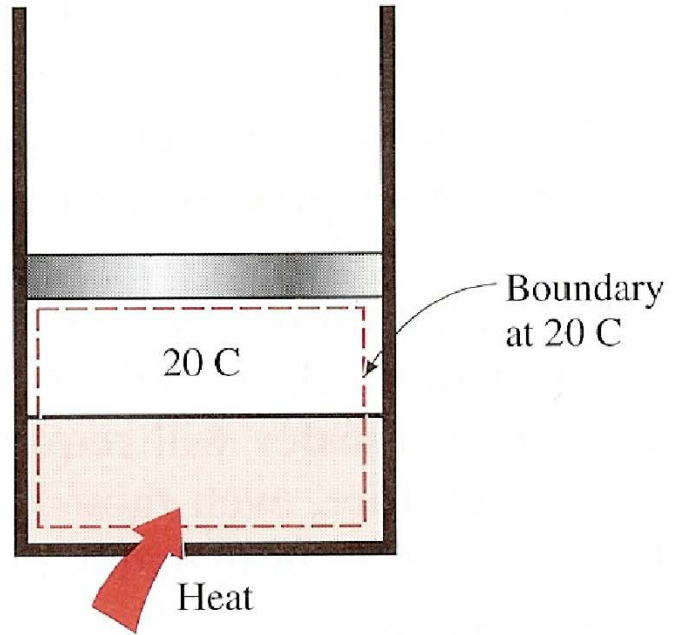

Thermal energy
reservoir at 30 C

(b) Internally reversible

THE CARNOT CYCLE

We mentioned earlier that heat engines are cyclic devices and that the working fluid of a heat engine returns to its initial state at the end of each cycle. Work is done by the working fluid during one part of the cycle and on the working fluid during another part. The difference between these two is the net work delivered by the heat engine. The efficiency of a heat-engine cycle greatly depends on how the individual processes that make up the cycle are executed. The net work, thus the cycle efficiency, can be maximized by using processes that require the least amount of work and deliver the most, that is, by using *reversible processes*.

Therefore, it is no surprise that the most efficient cycles are reversible cycles, i.e., cycles that consist entirely of reversible processes.

Reversible cycles cannot be achieved in practice because the irreversibilities associated with each process cannot be eliminated. However, reversible cycles provide upper limits on the performance of real cycles. Heat engines and refrigerators that work on reversible cycles serve as models to which actual heat engines and refrigerators can be compared. Reversible cycles also serve as starting points in the development of actual cycles and are modified as needed to meet certain requirements.

Probably the best known reversible cycle is the Carnot cycle, first proposed in 1824 by a French engineer Sadi Carnot. [The theoretical heat engine that operates on the Carnot cycle is called the Carnot heat engine.](#)

The Carnot cycle is composed of four reversible processes—two isothermal and two adiabatic.

Consider a closed system that consists of a gas contained in an adiabatic piston-cylinder device, as shown in figure below. The insulation of the cylinder head is such that it may be removed to bring the cylinder into contact with reservoirs to provide heat transfer.

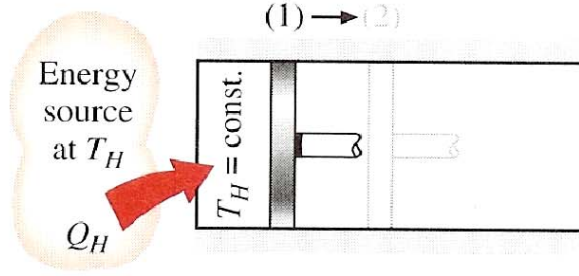

(a) Process 1-2

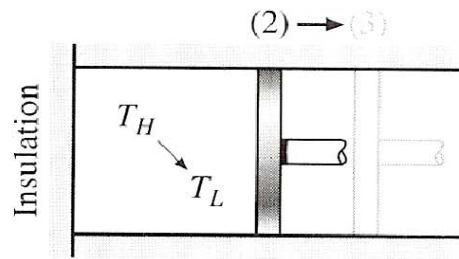

(b) Process 2-3

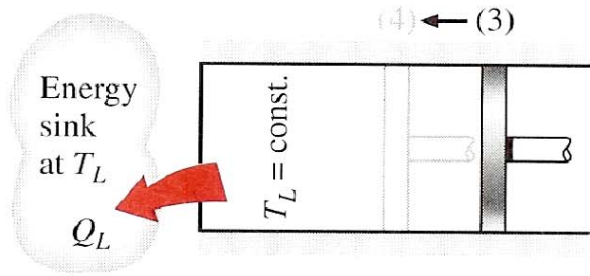

(c) Process 3-4

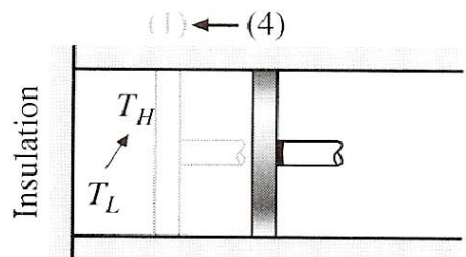

(d) Process 4-1

The four reversible processes that make up the Carnot cycle are as follows:

- **Reversible isothermal expansion** (process 1-2, $T_H = \text{constant}$). Initially (state 1) the temperature of the gas is T_H , and the cylinder head is in close contact with a source at temperature T_H . The gas is allowed to expand slowly, doing work on the surroundings. As the gas expands, the temperature of the gas tends to decrease. But as soon as the temperature drops by an infinitesimal amount dT , some heat flows from the reservoir into the gas, raising the gas temperature to T_H . Thus, the gas temperature is kept constant at T_H . Since the temperature difference between the gas and the reservoir never exceeds a differential amount dT , this is a reversible heat transfer process. It continues until the piston reaches position 2. The amount of total heat transferred to the gas during this process is Q_H .

For an ideal gas,

$$Q_H = -W_{12} = \int_{V_1}^{V_2} PdV = nRT_H \ln\left(\frac{V_2}{V_1}\right) \quad 3-9$$

- **Reversible adiabatic expansion** (process 2-3, temperature drops from T_H to T_L). At state 2, the reservoir that was in contact with the cylinder head is removed and replaced by insulation so that the system becomes adiabatic. The gas continues to expand slowly, doing work on the surroundings until its temperature drops from T_H to T_L (state 3). The piston is assumed to be frictionless and the process to be quasi-equilibrium, so the process is reversible as well as adiabatic. Since the gas is ideal and the process is adiabatic, $Q = 0$, So, by the first law

$$W_{23} = \Delta U = n C_V (T_L - T_H) \quad 3-10$$

- **Reversible isothermal compression** (process 3-4, $T_L = \text{constant}$). At state 3, the insulation at the cylinder head is removed, and the cylinder is brought into contact with a sink at temperature T_L . Now the piston is pushed inward by an external force, doing work on the gas. As the gas is compressed, its temperature tends to rise. But as soon as it rises by an infinitesimal amount dT , heat flows from the gas to the sink, causing the gas temperature to drop to T_L . Thus, the gas temperature is maintained constant at T_L . Since the temperature difference between the gas and the sink never exceeds a differential amount dT , this is a

reversible heat transfer process. It continues until the piston reaches position 4. The amount of heat rejected from the gas during this process is Q_L .

$$Q_L = -W_{34} = -\int_{V_3}^{V_4} P dV = -nRT_L \ln\left(\frac{V_4}{V_3}\right) \quad 3-11$$

- **Reversible adiabatic compression** (process 4-1, temperature rises from T_L to T_H). State 4 is such that when the low-temperature reservoir is removed and the insulation is put back on the cylinder head and the gas is compressed in a reversible manner, the gas returns to its initial state (state 1). The temperature rises from T_L to T_H during this reversible adiabatic compression process, which completes the cycle.

$$W_{41} = \Delta U = n C_V (T_H - T_L) \quad 3-12$$

The P - V diagram of this cycle is shown below.

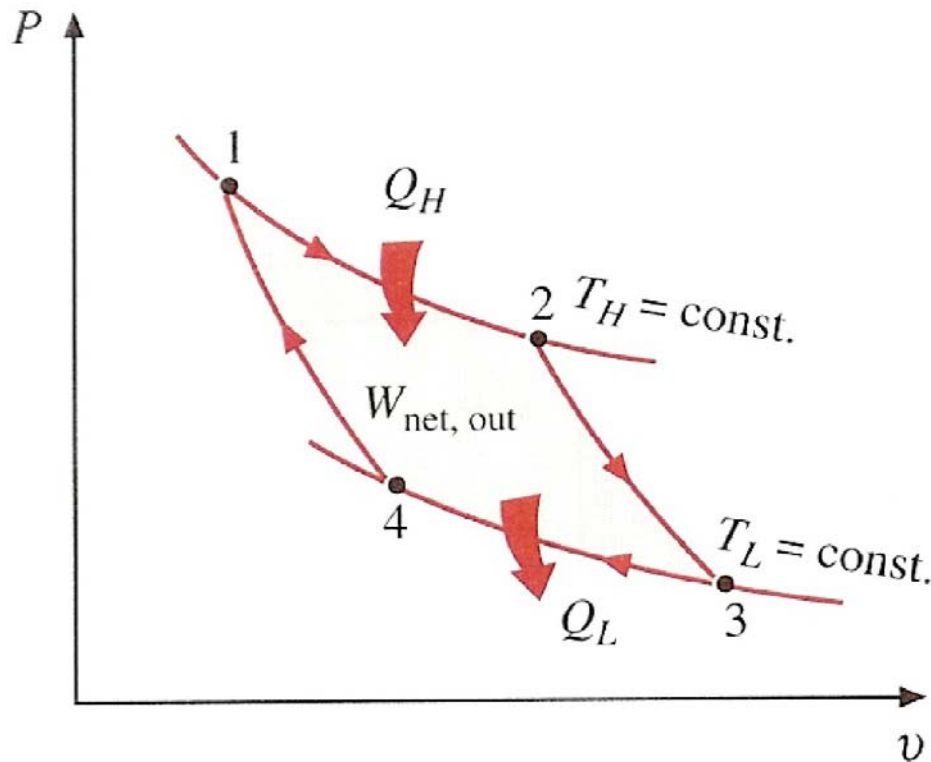

Remembering that on a P - V diagram the area under the process curve represents the boundary work for quasi-equilibrium (internally reversible) processes, we see that the area

under curve 1-2-3 is the work done by the gas during the expansion part of the cycle, and the area under curve 3-4-1 is the work done on the gas during the compression part of the cycle. The area enclosed by the path of the cycle (area 1-2-3-4-1) is the difference between these two and represents the net work done during the cycle.

The total work produced during the cycle is the sum of individual for in each cycle. By adding the above four equations we get

$$W_{net,out} = nR \left[T_H \ln \left(\frac{V_1}{V_2} \right) - T_L \ln \left(\frac{V_4}{V_3} \right) \right] \quad 3-13$$

From the first law,

$$\Delta U = Q + W = 0$$

or

$$Q = -W,$$

Then

$$Q_H - Q_L = -W_{net,out} = -nR \left[T_H \ln \left(\frac{V_1}{V_2} \right) - T_L \ln \left(\frac{V_4}{V_3} \right) \right] \quad 3-14$$

Thus, the work output of the engine is equal to the heat absorbed by the system.

Since V_1 and V_4 lie on one adiabat, and V_2 and V_3 on the other we can write

$$\left(\frac{V_4}{V_1} \right)^{\gamma-1} = \frac{T_L}{T_H}$$

$$\left(\frac{V_3}{V_2} \right)^{\gamma-1} = \frac{T_L}{T_H}$$

which gives

$$\frac{V_4}{V_1} = \frac{V_3}{V_2} \quad \text{or} \quad \frac{V_4}{V_3} = \frac{V_1}{V_2}$$

$$-W_{net,out} = -nR \left[T_H \ln\left(\frac{V_1}{V_2}\right) - T_L \ln\left(\frac{V_1}{V_2}\right) \right] = -nR(T_H - T_L) \ln\left(\frac{V_1}{V_2}\right) \quad 3-15$$

Dividing Eq 3-15 by 3-9 we get

$$\frac{-W_{net,out}}{Q_H} = \frac{T_H - T_L}{T_H} \quad 3-16$$

or

$$\frac{Q_H - Q_L}{Q_H} = \frac{T_H - T_L}{T_H} \quad 3-17$$

The efficiency of a Carnot engine operating in reversible cycles is therefore

$$\eta = 1 - \frac{Q_L}{Q_H} = 1 - \frac{T_L}{T_H} \quad 3-18$$

It should be noted that no heat engine is 100% efficient. If the rejected heat were included as part of its output, the efficiency of every engine would be 100%.

The above definition of efficiency applies to every type of heat engine; it is not restricted to the Carnot engine only.

Since every step in this cycle is carried out reversibly, the maximum possible work is obtained for the particular working substance and temperature considered.

It can be shown that no other engine working between the same two temperatures can convert thermal energy to mechanical energy with a greater efficiency than does the Carnot engine. Other reversible engines, in fact, will have the same efficiency as the Carnot engine.

Notice that if we acted stingily and compressed the gas at state 3 adiabatically instead of isothermally in an effort *to save* Q_L , we would end up back at state 2, retracing the process path 3-2. By doing so we would save Q_L , but we would not be able to obtain any net work output from this engine. This illustrates once more the necessity of a heat engine

exchanging heat with at least two reservoirs at different temperatures to operate in a cycle and produce a net amount of work.

The Reversed Carnot Cycle

The Carnot heat-engine cycle described above is a totally reversible cycle. Therefore, all the processes that comprise it can be *reversed*, in which case it becomes the **Carnot refrigeration cycle**. This time, the cycle remains exactly the same, except that the directions of any heat and work interactions are reversed: Heat in the amount of Q_L is absorbed from the low-temperature reservoir, heat in the amount of Q_H is rejected to a high-temperature reservoir, and a work input of $W_{net,in}$ is required to accomplish all this.

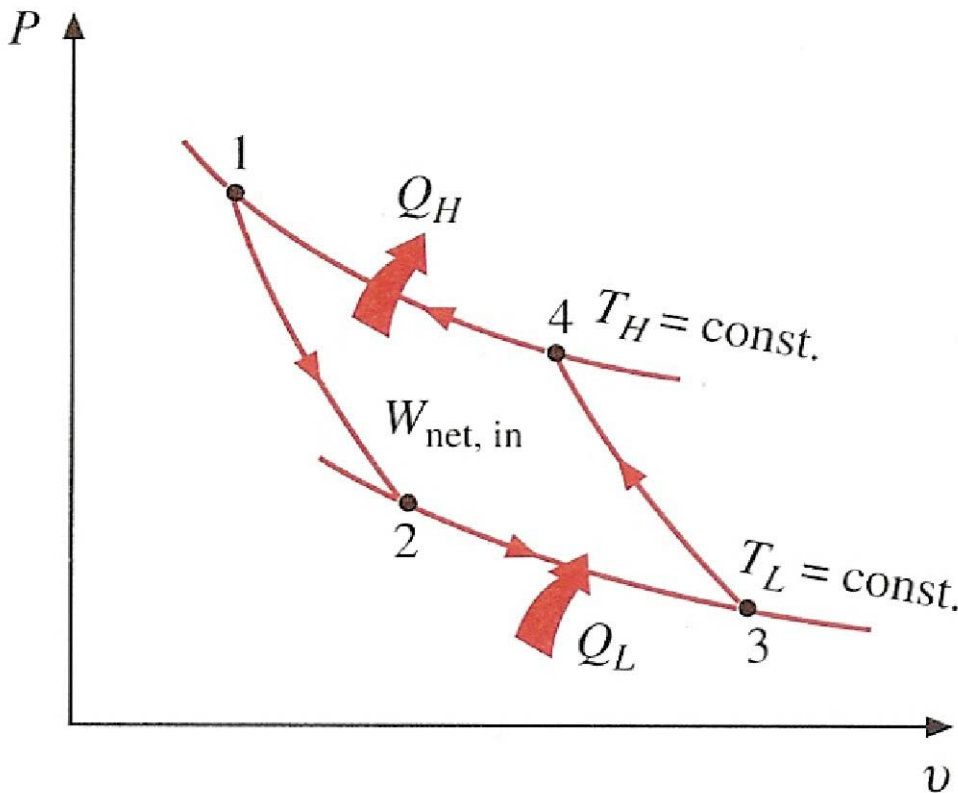

Remember, for a refrigerator, the efficiency is termed Coefficient of Performance (see Eq. 3-6) and can be larger than 100%.

Being a reversible cycle, the Carnot cycle is the most efficient cycle operating between two specified temperature limits. Even though the Carnot cycle cannot be achieved in reality, the efficiency of actual cycles can be improved by attempting to approximate the Carnot cycle more closely.

THE CARNOT PRINCIPLES

The second law of thermodynamics places limitations on the operation of cyclic devices as expressed by the Kelvin-Planck and Clausius statements. A heat engine cannot operate by exchanging heat with a single reservoir, and a refrigerator cannot operate without a net work input from an external source.

We can draw valuable conclusions from these statements. Two conclusions pertain to the thermal efficiency of reversible and irreversible (i.e., actual) heat engines, and they are known as the Carnot principles.

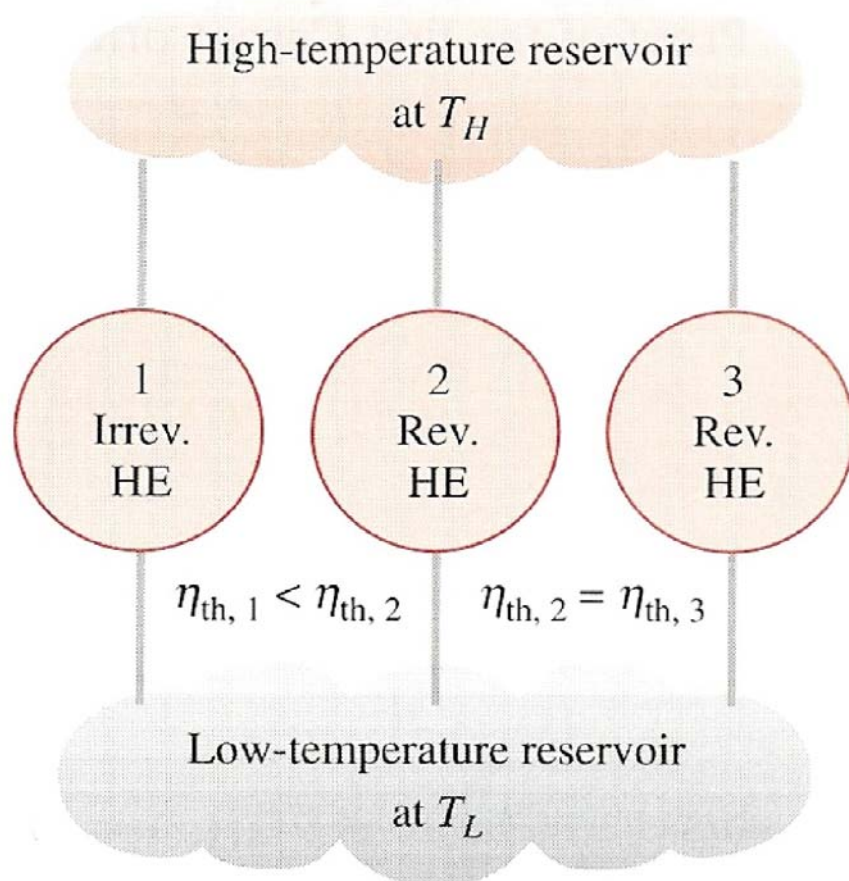

They are expressed as follows:

1 The efficiency of an irreversible heat engine is always less than the efficiency of a reversible one operating between the same two reservoirs.

2 The efficiencies of all reversible heat engines operating between the same two reservoirs are the same.

These two statements can be proved by demonstrating that the violation of either statement results in the violation of the second law of thermodynamics.

To prove the first statement, consider two heat engines operating between the same reservoirs, as shown below.

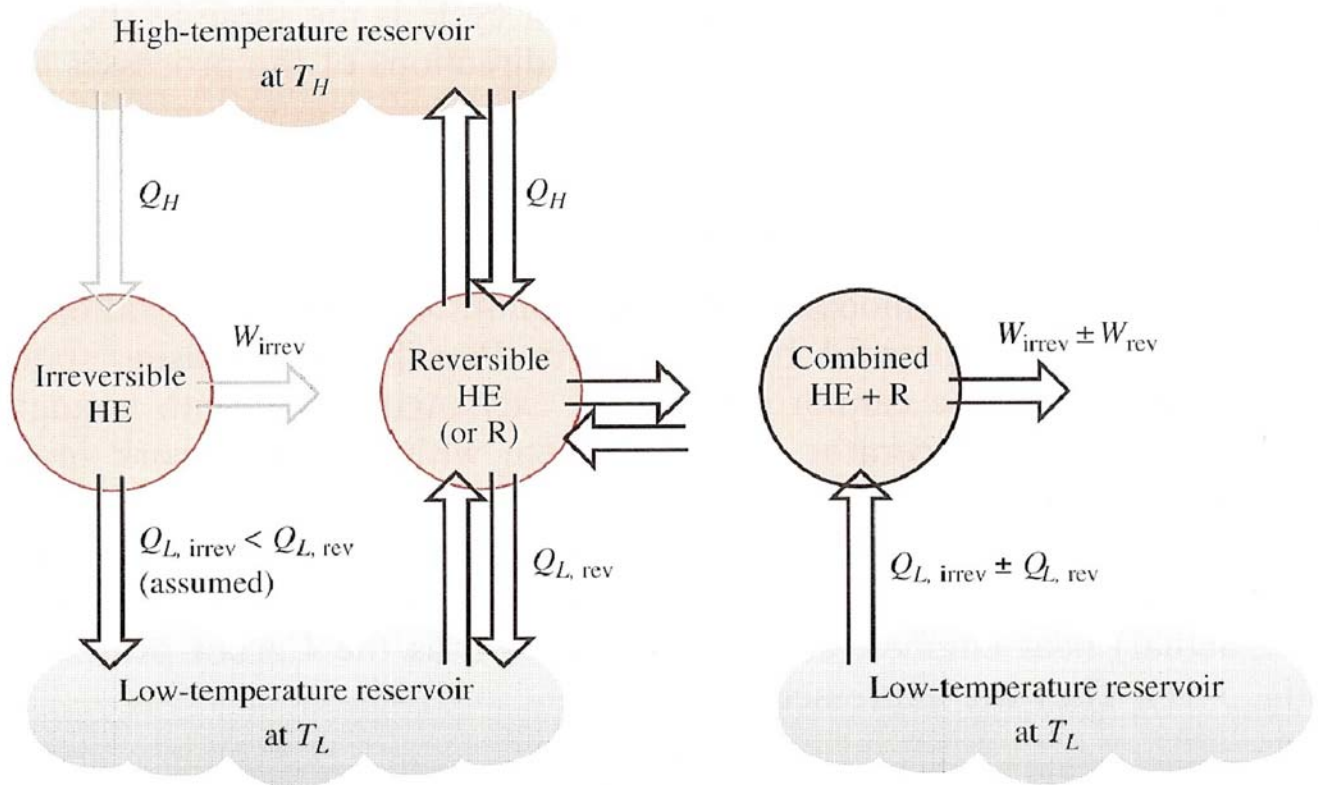

(a) A reversible and an irreversible heat engine operating between the same two reservoirs (the reversible heat engine is then reversed to run as a refrigerator)

(b) The equivalent combined system

a. One engine is reversible, and the other is irreversible. Now each engine is supplied with the same amount of heat Q_H . The amount of work produced by the reversible heat engine is W_{rev} , and the amount produced by the irreversible one is W_{irrev}

b. In violation of the first Carnot principle, we assume that the irreversible heat engine is more efficient than the reversible one (that is, $\eta_{irrev} > \eta_{rev}$) and thus delivers more work than the reversible one.

c. Now let the reversible heat engine be reversed and operate as a refrigerator. This refrigerator will receive a work input of W_{rev} and reject heat to the high-temperature reservoir.

d. Since the refrigerator is rejecting heat in the amount of Q_H to the high-temperature reservoir and the irreversible heat engine is receiving the same amount of heat from this reservoir, the net heat exchange for this reservoir is zero. Thus it could be eliminated by having the refrigerator discharge Q_H directly into the irreversible heat engine.

e. Now considering the refrigerator and the irreversible engine together, we have an engine that produces a net work in the amount of $W_{irrev} - W_{rev}$ while exchanging heat with a single reservoir- a violation of the Kelvin-Planck statement of the second law. Therefore, our initial assumption that $\eta_{irrev} > \eta_{rev}$ is incorrect. Then we conclude that no heat engine can be more efficient than a reversible heat engine operating between the same reservoirs.

Note: The second Carnot principle can also be proved in a similar manner. This time, let us replace the irreversible engine by another reversible engine that is more efficient and thus delivers more work than the first reversible engine. By following through the same reasoning as above, we will end up having an engine that produces a new amount of work while exchanging heat with a single reservoir, which is a violation of the second law. Therefore we conclude that no reversible heat engine can be more efficient than another reversible heat engine operating between the same two reservoirs, regardless of how the cycle is completed or the kind of working fluid used.

Example 3.2

1 mol of a perfect gas is subjected to all the steps of a reversible Carnot cycle. Calculate T , P , V and H at the end of each step. Assume that C_P and C_V are constants.

Solution

See text page 128-129